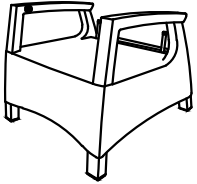
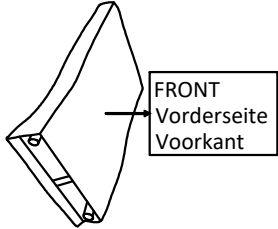
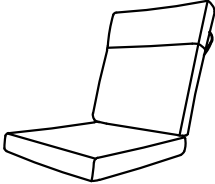
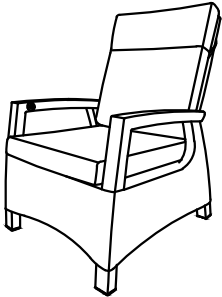

Assembly Instructions

IMPORTANT,RETAIN FOR FUTURE REFERENCE:READ CAREFULLY

Caution: Assemble only with assistance from adults.Do not assemble in presence of children and or being assisted by a child.

Parts:	A 	B 	C 	
Parts Description	Recliner seat	Recliner back	Seat & Backrest Cushion	
Quantity	1pc	1pc	1pc	

Assembly Instructions

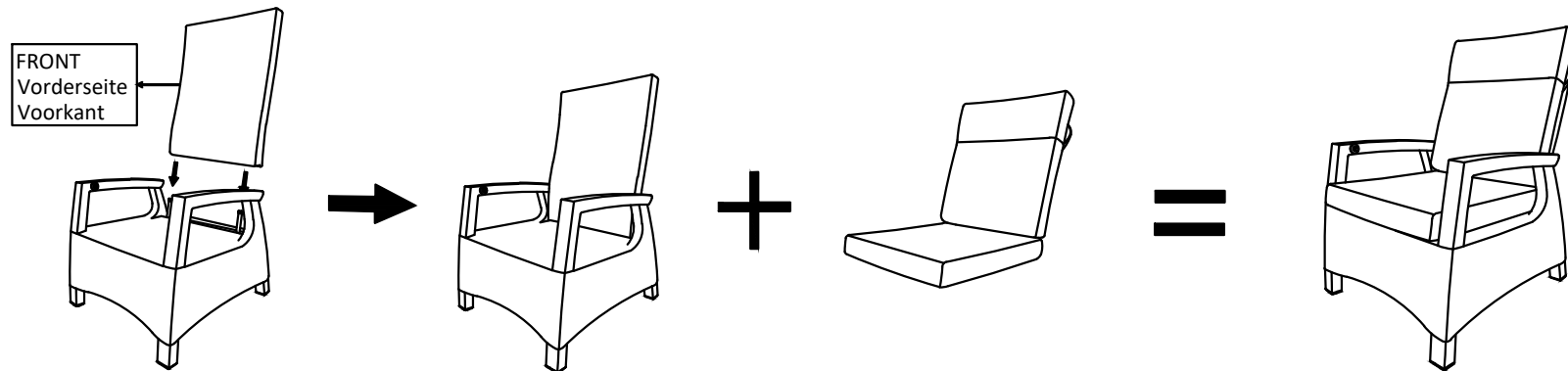

Step 1.Take out all the components and place them onto a soft and clean surface.put the recliner seat(A) in its upright position.Hold up the recliner back(B)and aim the tubes located at the underside of the backrest,and Plug-slot into the 02 tubes which are on the seat base.Push firmly and fully downwards

Step2.Put the cushion (C)onto the chair,as shown in the picture

Step3.Make sure every Part is connected well and this Recliner Chair is ready for use

What to do if the gas spring for adjusting the backrest does not work or does not work properly.
Wat te doen als de gasveer voor het verstellen van de rugleuning niet of niet goed functioneert.
Was ist zu tun, wenn die Gasfeder zum Verstellen der Rückenlehne nicht oder nicht richtig funktioniert.



Situation A
Situatie A
Situation A

Backrest automatically returns to the starting position
Rugleuning gaat automatisch weer naar de begin positie
Rückenlehne kehrt automatisch in die Ausgangsposition zurück

Step 1: Loosen the nut (b) 1-2 mm.
Step 2: Slide the gas spring cable up 1-2mm in the direction indicated by the arrow below.
Step 3: Tighten the nut (a).

Stap 1: Draai de moer (b) 1-2 mm los.
Stap 2: Schuif de kabel van de gasveer 1-2mm op in de richting die de pijl hieronder aangeeft.
Stap 3: Draai de moer (a) aan.

Schritt 1: Lösen Sie die Mutter (b) um 1-2 mm.
Schritt 2: Schieben Sie das Bowdenzug 1-2 mm in die durch den Pfeil unten angegebene Richtung.
Schritt 3: Ziehen Sie die Mutter (a) an.

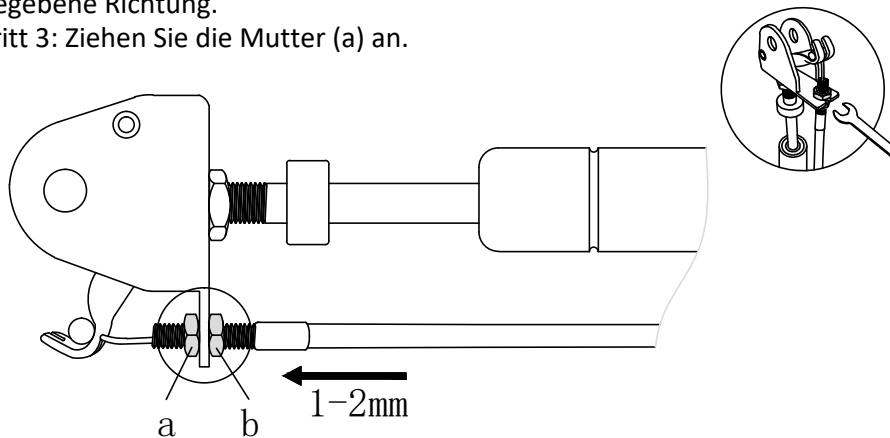

Situation B
Situatie B
Situation B

Backrest can't be adjusted, or barely adjusted
Rugleuning kan niet of nauwelijks versteld worden
Die Rückenlehne ist nicht oder kaum verstellbar

Step 1: Loosen the nut (a) 1-2 mm.
Step 2: Slide the gas spring cable up 1-2mm in the direction indicated by the arrow below.
Step 3: Tighten the nut (b).

Stap 1: Draai de moer (a) 1-2 mm los.
Stap 2: Schuif de kabel van de gasveer 1-2mm op in de richting die de pijl hieronder aangeeft.
Stap 3: Draai de moer (b) aan.

Schritt 1: Lösen Sie die Mutter (a) um 1-2 mm.
Schritt 2: Schieben Sie das Bowdenzug 1-2 mm in die durch den Pfeil unten angegebene Richtung.
Schritt 3: Ziehen Sie die Mutter (b) an.

